

WHEEL LOAD [KG]

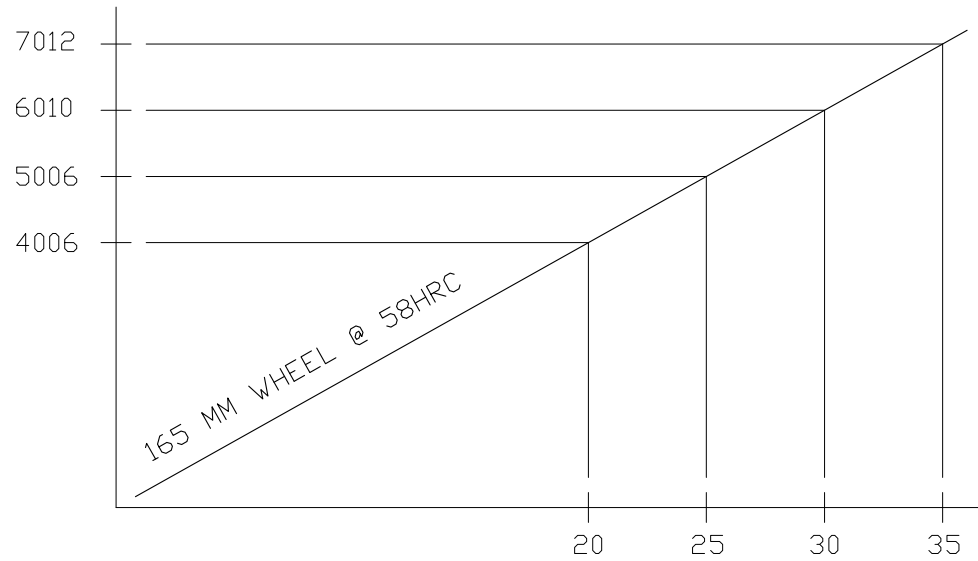

THE MAX WHEEL LOAD IS A COMBINED FUNCTION OF THE FOLLOWING FACTORS

- RUNWAY ACCURACY
- CRANE ACCURACY
- DUTY CYCLE
- OPERATING CONDITIONS
- COMPONENT STRESS LIMITS

IT IS RECOMMENDED TO ADHERE TO THE CHART FOR WHEEL LOAD LIMITATIONS BUT THE WHEEL LOAD REQUIREMENTS CAN BE DERATED BASED ON SPECIFIC DUTY CYCLE APPLICATION

RAIL WIDTH [MM]

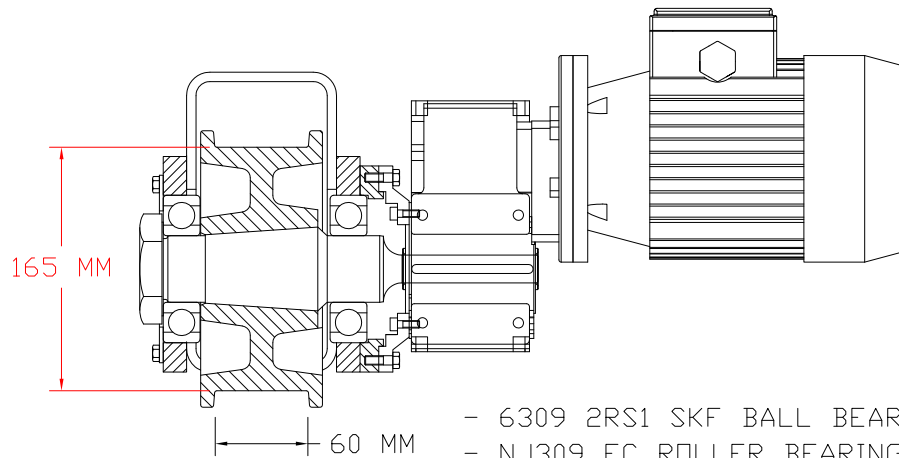

- 6309 2RS1 SKF BALL BEARINGS (STANDARD)
- NJ309 EC ROLLER BEARINGS (OPTIONAL) FOR SHOCK LOADING APPLICATIONS



DETROIT HOIST & CRANE CO.

MAXIMUM WHEEL LOAD CHART  
ACCORDING TO CMAA TABLE 4.7.1-4  
165 MM WHEEL ( GRAPHITE DUCTILE IRON )

CHART#

HRC-6M

DRAWN BY / DATE

A.B. / 04-29-09

NOTE: X

NOTE: X

NOTE: X

SCALE 1:X

DIRECTORY \

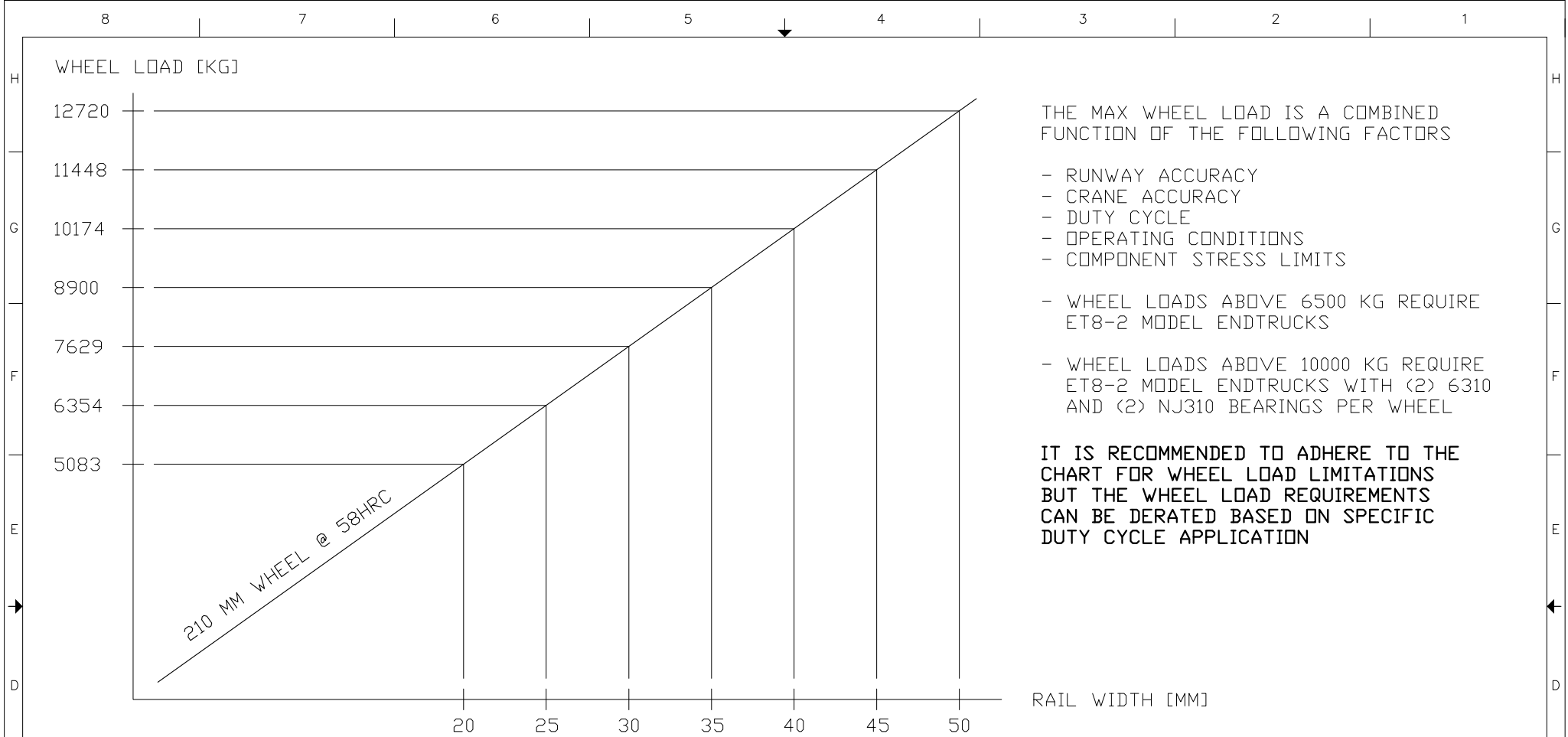

- THE MAX WHEEL LOAD IS A COMBINED FUNCTION OF THE FOLLOWING FACTORS
- RUNWAY ACCURACY
  - CRANE ACCURACY
  - DUTY CYCLE
  - OPERATING CONDITIONS
  - COMPONENT STRESS LIMITS
- WHEEL LOADS ABOVE 6500 KG REQUIRE ET8-2 MODEL ENDTRUCKS
  - WHEEL LOADS ABOVE 10000 KG REQUIRE ET8-2 MODEL ENDTRUCKS WITH (2) 6310 AND (2) NJ310 BEARINGS PER WHEEL

IT IS RECOMMENDED TO ADHERE TO THE CHART FOR WHEEL LOAD LIMITATIONS BUT THE WHEEL LOAD REQUIREMENTS CAN BE DERATED BASED ON SPECIFIC DUTY CYCLE APPLICATION

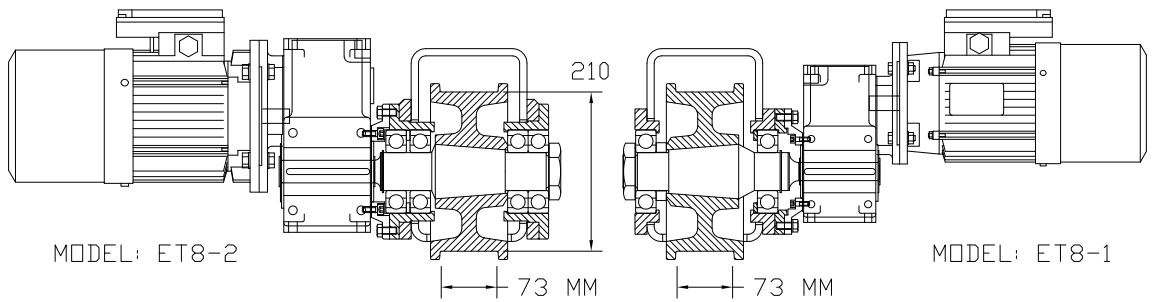

- 6310 2RS1 SKF BALL BEARINGS (STANDARD)
- NJ310 EC ROLLER BEARING (OPTIONAL) FOR SHOCK LOADING APPLICATIONS

**DETROIT HOIST & CRANE CO.**

MAXIMUM WHEEL LOAD CHART  
 ACCORDING TO CMAA TABLE 4.13.3-4  
 210 MM WHEEL ( GRAPHITE DUCTILE IRON )

CHART# HRC-8M	DRAWN BY / DATE A.B. / 04-29-09
------------------	------------------------------------

WHEEL LOAD [KG]

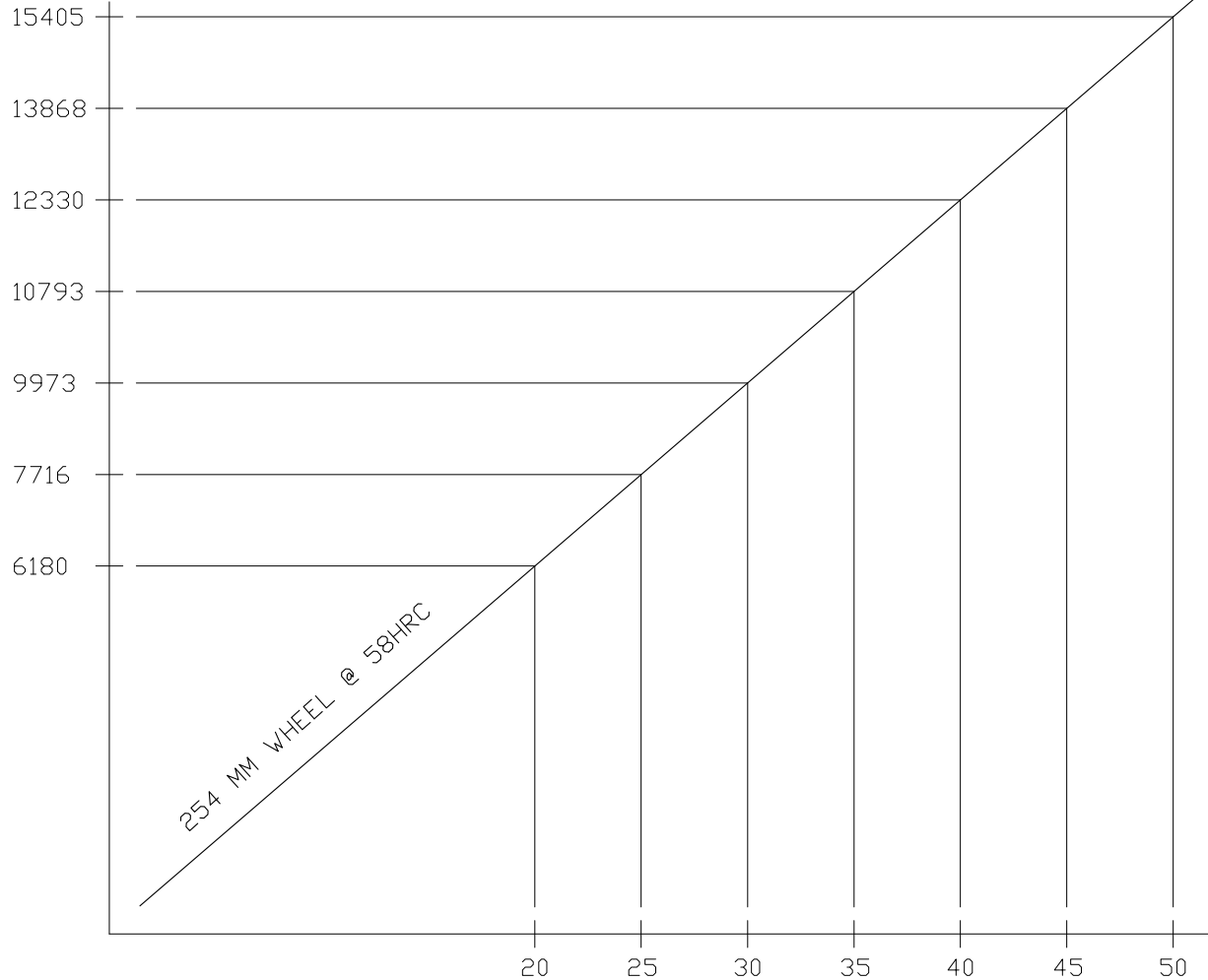

254 MM WHEEL @ 58HRC

THE MAX WHEEL LOAD IS A COMBINED FUNCTION OF THE FOLLOWING FACTORS

- RUNWAY ACCURACY
- CRANE ACCURACY
- DUTY CYCLE
- OPERATING CONDITIONS
- COMPONENT STRESS LIMITS

IT IS RECOMMENDED TO ADHERE TO THE CHART FOR WHEEL LOAD LIMITATIONS BUT THE WHEEL LOAD REQUIREMENTS CAN BE DERATED BASED ON SPECIFIC DUTY CYCLE APPLICATION

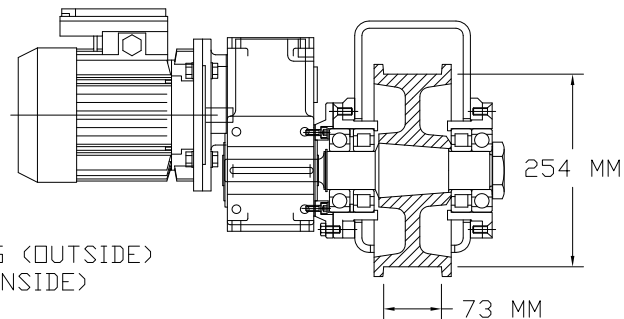

- 6310 2RS1 SKF BALL BEARING (OUTSIDE)
- NJ310 EC ROLLER BEARING (INSIDE)

DETROIT HOIST & CRANE CO.

MAXIMUM WHEEL LOAD CHART  
ACCORDING TO CMAA TABLE 4.13.3-4  
254 MM WHEEL ( GRAPHITE DUCTILE IRON )

CHART#  
HRC-10M

DRAWN BY / DATE  
A.B. / 04-29-09

NOTE: X

NOTE: X

NOTE: X

SCALE 1:X

DIRECTORY \

WHEEL LOAD [KG]

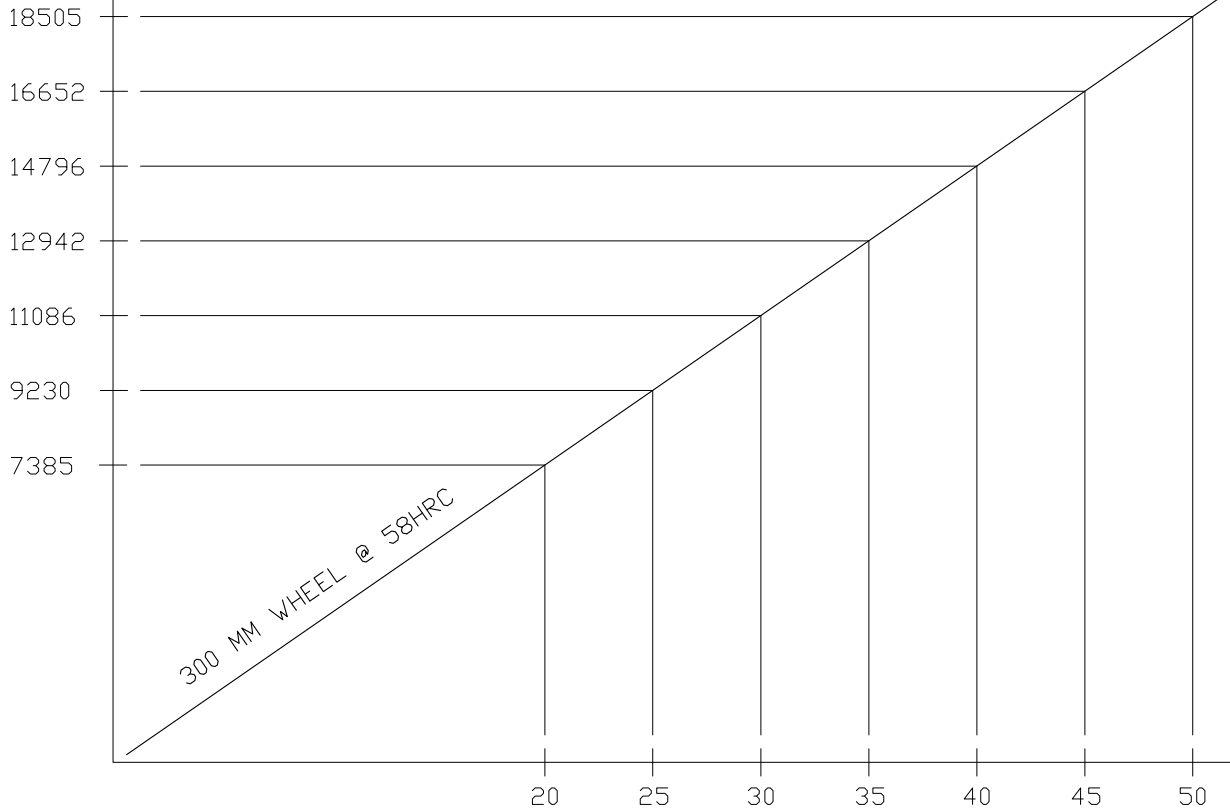

THE MAX WHEEL LOAD IS A COMBINED FUNCTION OF THE FOLLOWING FACTORS

- RUNWAY ACCURACY
- CRANE ACCURACY
- DUTY CYCLE
- OPERATING CONDITIONS
- COMPONENT STRESS LIMITS

IT IS RECOMMENDED TO ADHERE TO THE CHART FOR WHEEL LOAD LIMITATIONS BUT THE WHEEL LOAD REQUIREMENTS CAN BE DERATED BASED ON SPECIFIC DUTY CYCLE APPLICATION

RAIL WIDTH [MM]

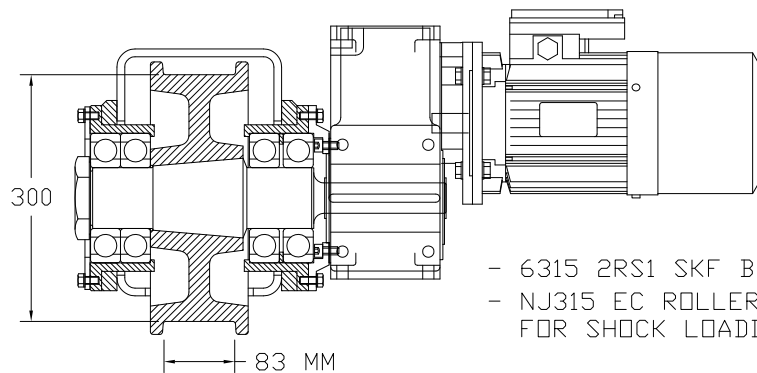

- 6315 2RS1 SKF BALL BEARINGS (STANDARD)
- NJ315 EC ROLLER BEARINGS (OPTIONAL) FOR SHOCK LOADING APPLICATION



DETROIT HOIST

MAXIMUM WHEEL LOAD CHART  
ACCORDING TO CMAA TABLE 4.13.3-4  
300" WHEEL ( GRAPHITE DUCTILE IRON )

CHART#

HRC-12M

DRAWN BY / DATE

A.B. / 04-29-09

NOTE: X

NOTE: X

NOTE: X

SCALE 1:X

DIRECTORY \